

Chapter Eight

Digital Imaging and Mapping

8. Analog vs. digital imaging

From its inception, the SEM has been widely used to produce "images" of an area scanned by the electron beam. Prior to the development of high-speed electronics working together with mini- or micro-computers, the images were strictly *analog images*. We use the term *analog* here in the sense of traditional means of SEM image acquisition, however *analog* electronics (variable voltage) did operate the SEM circuit boards. In the "traditional" sense, imaging anticipated the photographic darkroom and wet chemistry ... or for the sake of convenience, a Polaroid® 4X5 inch camera back which copied a *photo CRT*. Recently however, advances in solid-state electronics that produced the "computer revolution" have also revolutionized the use of electron-beam instruments. For the purposes of this chapter, the most significant result has been the development of the capability to collect *digital images* of all signals collected by the instrument, including SE, BSE, cathodo-luminescence and X-ray signals.

We define *maps* separate from *images*, but sometimes use the terms interchangeably. We reserve *maps* for spatial representations which usually implies the object is flat. Since backscattered images are typically of specimens which are polished flat, we will commonly call them maps. Spatial elemental distributions are always referred to as maps, as in *elemental maps*.

8.1 Analog images

Before discussing digital images in detail, it might be helpful to first describe analog images, how they are produced and their limitations. The production of an analog image on a CRT screen involves synchronizing of the beam *scan generator* with the CRT. Scanning of the electron beam over the specimen is accomplished with two sets of *scanning coils* located around the electron column between the condenser and objective lenses. The two scanning coils are oriented at right angles to one another. One set will deflect, or position, the beam in the horizontal (X) direction on the target, while the other positions the beam in the vertical (Y) direction. The two scan coils are controlled by a *scan generator* which governs the current flowing through the

coils and hence the amount and direction of beam deflection. In essence, the beam can be moved in any trajectory as defined by the scan generator. For example, if both the X and Y scan coils receive a sine wave form from the scan generator, the beam will move in a circle.¹ For our purposes, the primary function of the scan generator is to raster the beam over an area on the sample with the same aspect ratio as that of the CRT. This is typically done by sending a "sawtooth" (analog) voltage to both sets of scan coils. Figure 8-1 illustrates how a horizontal 2 millisecond sawtooth waveform can be combined with a vertical 2 second sawtooth to produce a **slow** 2 second display scan. The "ramp" part of the sawtooth controls the electromagnetic scanning coils which direct the beam across the target, the time taken to do so depends on the frequency of the waveform produced by the scan generator. The vertical part of the sawtooth instantly sends the beam back to the beginning of the "raster" scan. Typical analog scan rates, or rasters, include a *TV rate* which is approximately analogous to a television raster rate, or a *slow rate*, for which the scan rate in the horizontal direction is fast (e.g., 2 milliseconds), but the vertical scan rate is on the order of 2 to 20 seconds. The result of the latter is a horizontal line traveling from the top of the display to the bottom in 2 to 20 seconds. The term *analog* generally refers to the ramp part of the sawtooth being smooth or continuous ... that is, the ramp and its influence on the beam is controlled by an analog voltage.

¹ As an aside, modern micro-circuit boards are constructed by first etching the pattern onto a silicon wafer by controlling the scan generator by a computer program for tracing all of the intricate pathways.

Although unrelated to imaging, you should be aware of the fact that some individuals and labs have suggested rastering the beam over a specimen as a substitute for defocusing the beam for applications that call for a broad or dispersed beam. For example, an EPMA analyst might want to probe a larger area on your specimen because of the detrimental effects of a focused beam. The use of a rastered beam has the advantage that the operator can see (e.g., with the BSE image) precisely what he or she is analyzing.

We discourage use of a rastered beam for quantitative analysis, not only because the matrix corrections on the x-ray intensities will not produce quantitative results using “averaged” x-ray intensities, but also because the scan rate timing involves a “wait-to-start-frame” signal at the beginning of each scan, as well as a “wait-to-start-line” at the beginning of each horizontal line. This means that the electron beam will be stationary (usually in the upper-left-hand corner and along the left edge) for a fraction of a second before it is given the signal to begin a new raster. This means that the time the beam spends on the target is not evenly distributed across the area that is being analyzed. A chemical analysis based on a rastered beam technique will therefore be

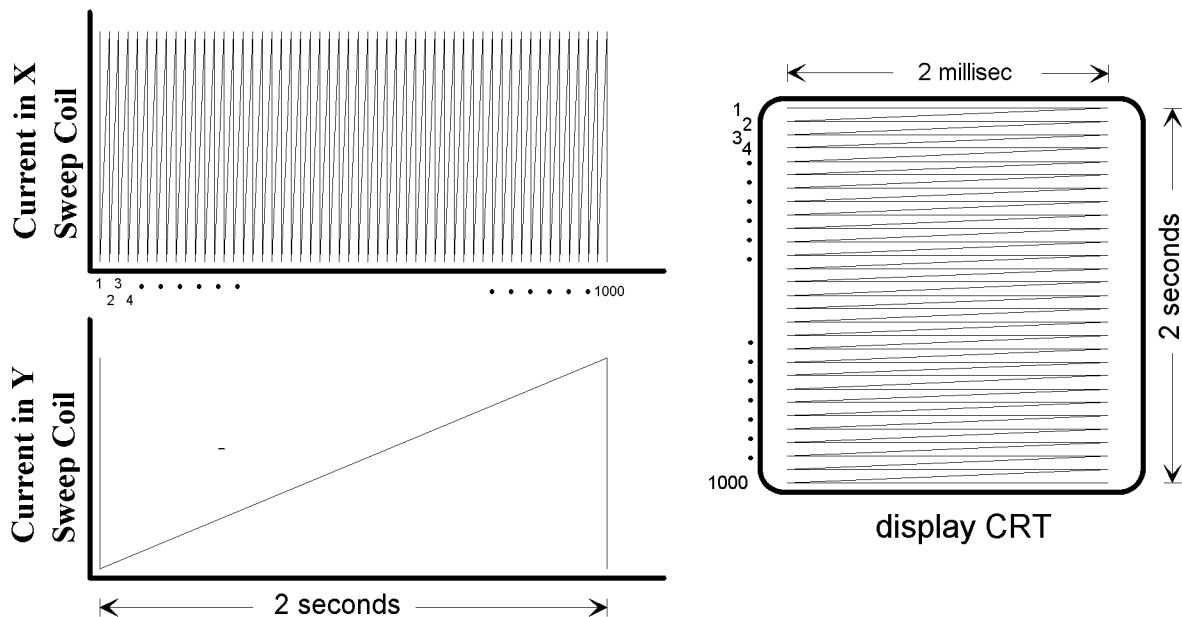

Figure 8-1 Schematic representation of analog scan control signals for both the horizontal and vertical scan coils. This figure is specifically for a 1000 line 2 second scan. If these scan coils were controlled digitally, then instead of sawtooth ramps imagine staircases which would indicate the electron beam jumping from one spot to the next.

biased (weighted) to, or away from, the upper left corner and left edge of the area analyzed. This is obviously an unwanted bias if the sample is inhomogeneous. We recommend that you not use this technique, and furthermore suggest caution in applying or accepting the published results of others who have used rastered beam analysis.

At the same time the beam is scanning over the specimen, the electron gun in the CRT is producing a beam of electrons that "scan" over the phosphor of the tube. The scanning coils in the CRT are also driven by the scan generator, so for each instantaneous beam position there is a corresponding position on the CRT. In one sense, the resolution that can be achieved is limited by the CRT. If the CRT is capable of displaying 1000 lines, the image is built up of 1000 lines and each line is composed of 1000 non-overlapping "points". If the CRT has an area of 10 x 10 cm, the width of each line is 0.1mm, about the minimum dimension that can be resolved by the human eye (this minimum line width is defined as a black line on a perfectly white background).

The output of any one of the various detectors (e.g., SE or BSE) can be selected and relayed to the CRT's "brightness control" or "Z" axis. The rate of scan over the sample is very slow relative to the time required for the electron beam to interact with the specimen, generate signals, and for those signals to be electronically processed and relayed to the CRT brightness control. Consequently a "one-to-one" correspondence can be established between the strength of the signal (voltage) from each point on the sample and the CRT brightness while both "spots" are still at the X-Y coordinates of the source. The way this works is to have the CRT's beam current *modulated* by the output of the SE or BSE detector.

The obvious disadvantage to a purely analog image is that is strictly temporary. A bright point on a CRT will remain bright only as long as the phosphor maintains its state of activation. For the example described above (a 2 second scan), in order for the image to be seen in its entirety, the phosphor must be capable of holding its brightness for at least 2 seconds. The green color of most microprobe and SEM CRTs is due to the use of long-lasting phosphors.

Although modern CRTs have sufficiently high resolution and phosphor stability to yield good images, they obviously cannot produce permanent images. For this reason, EPMA and SEM instruments have for many years come equipped with a camera for recording images. On most instruments, this is a Polaroid camera so that the operator can obtain images during a working session. The Polaroid camera is actually attached to a separate, hidden CRT that has its scan coils and beam current controlled in the same manner as the main viewing CRT. This CRT has a "screen" the size of a sheet of Polaroid film (4.5 x 3.5") and a zero-lifetime phosphor. The brightness of each spot on this CRT exposes the film in one long-duration scan. In contrast to a typical CRT, a Polaroid film has a resolution of about 2000 lines, and hence is capable of achieving resolution better than that on a CRT. In addition to the Polaroid camera, sometimes a 35mm camera attachment is provided to allow for production of slides or prints.

Although "hard-copy" images can be produced with a camera, the utility of analog images is reduced because they are not amenable to any post-acquisition modification. Unless the photos are somehow "scanned" or photographed with a digital camera, "*what you see is what you get*". A major outgrowth of the "computer revolution" has been the development of electronics and computer software that allow enormous flexibility and capability for post-acquisition analysis of digital images.

8.2 Digital images

The acquisition of digital images and the post-acquisition analysis of digital images (image analysis) was made possible by the development of inexpensive, high-speed computers directly connected to the detectors found on a variety of instruments. In many respects, the advances made in digital imagery stem primarily from two very diverse fields of study: 1) satellite imagery and 2) medical imagery (e.g., CAT scans). We have all marveled at the fascinating, important and in many cases, life-saving, digital images produced in these disciplines over the past ten years.

The mineralogical, petrological and geochemical communities have been taking advantage of these new technologies by developing and applying digital imagery and image analysis to the SEM and EPMA.

The fundamental difference between an analog and a digital image is the nature of the signal actually used to produce the image. As noted above, an analog image is produced when signals from the scan generator (current) are used to simultaneously drive the X and Y coils of the CRT, **and** the signal from a preselected detector (volts) is used to simultaneously control, on a 1- to -1 basis, the "Z" axis (brightness) of the CRT. A digital image is similar in principle, but in its case the X, Y and Z coordinates are converted to a digital, or binary, form prior to being displayed or stored. For our purposes, the critical difference is that once an analog signal is converted into a digital "signature" it can be stored in computer memory and subsequently be used in a variety of applications or modified by any computer program capable of reading and processing such data.

We saw in Chapter 6 how the analog signal from an EDS detector is converted to a digital signal with an *analog-to-digital converter (ADC)*. An identical, or similar, ADC is used to convert the signal from the SE or BSE detector into the digital signal used for the "Z" (brightness) axis of the image. The opposite approach is taken for the X and Y axes. A *digital scan generator* is used as the primary input to the X and Y scanning coils of the electron beam, and to the computer. Since the scanning coils controlling both the primary beam and the analog CRT are necessarily analog in character (i.e., they require a constant current) the signal sent from the digital scan generator must first be converted into analog form by a *digital-to-analog converter (DAC)*. All scanning on both of our instruments is in fact governed by a digital scan generator. The use of a digital scan generator and an ADC on all output detectors provides the capability for all three dimensions, X, Y and "Z" (brightness), to be displayed and stored by the computer as digital (binary) data.

The components of our JEOL SEM are illustrated in Figure 8-2. Operation of the beam scanning coils and the analog CRT occurs as described above. Incorporation of a computer receiving digital data for X, Y and Z provides enormous capability and considerable flexibility for the user. As an area on the sample is being scanned by the electron beam, the X, Y and Z data are stored in a portion of computer memory known as the *Frame Memory* and manipulated by the computer's *Frame Integration System (FIS)*, and displayed on the *frame store monitor* or sent to a *window* on the computer display.

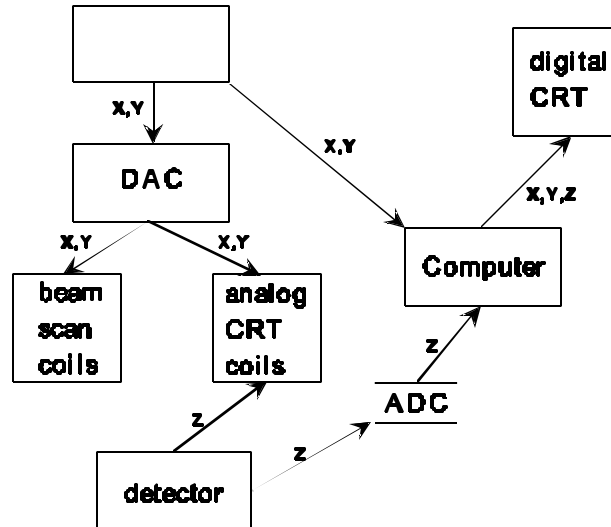

Figure 8-2 Block diagram for computer digital control of analog scan coils, or *digital scan generator*.

During collection of an image (i.e., during the scanning), the image is simultaneously displayed on the analog CRT and the binary data are temporarily stored in buffer memory (512 x 512 x 16 bits, 2 frames) and processed to improve the signal-to-noise ratio. Data from the first scan over an area (e.g., the first 2-sec. scan) is placed into the first of the two buffers. Subsequent scans are added to the first buffer, averaged by one of several algorithms, and then placed into the second buffer. In this manner, the digital image is built up "scan-by-scan" with each scan enhancing the previous scans. By averaging the data on successive scans the signal-to-noise ratio is greatly improved, because the averaging of random noise tends to cancel out most of the noise. The final digitized image can be displayed on the digital CRT as a "still image" and temporarily stored in frame memories, having 1024 x 1024 x 8 bit (or greater) storage capacity and eventually saved to disk as a digital image file for off-line processing.

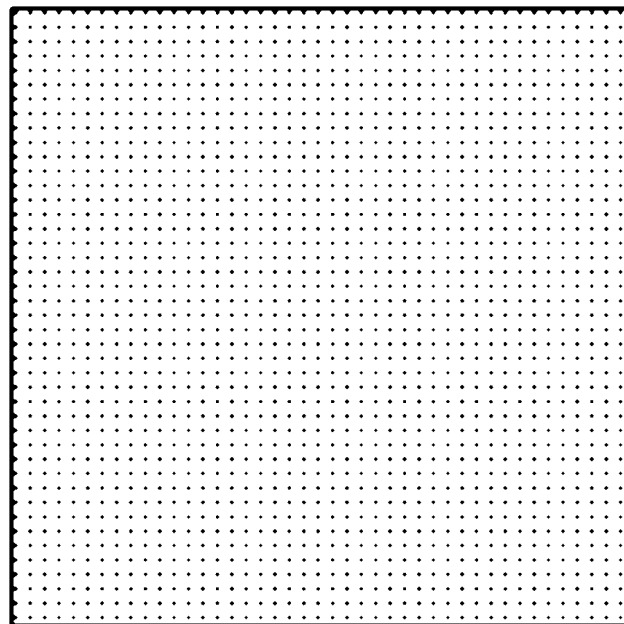

Figure 8-3 Schematic illustration of the grid or point array which represents the discrete location for each pixel acquisition.

Because many instrument image acquisition systems lack many of the post-acquisition, image analysis features present in many third-party, PC-based software packages, it will often be desirable to download your images from the SEM computer and process them off-line.

One difference between digital and analog image storage is important to keep in mind. With analog film, the sensitivity of the film to brightness is fixed by the film speed. Therefore it is possible to compare film brightness values between images, so long as the instrument and amplifier settings remain constant. However, with digital images, there is an extra degree of freedom that needs to be considered. That is, the process by which the analog data is converted to the digital data type. For example, 8 bit images can contain information for 256 "gray levels" in each 8 bit (1 byte) pixel. But it is all too easy to "normalize" the image data to fit the available bit depth range, so that the lowest intensity level actually measured is automatically represented by 0 (black for example) and the highest intensity level actually measured is represented by 255 (white for example). In this case, it is not appropriate to compare "absolute" image brightness between images.

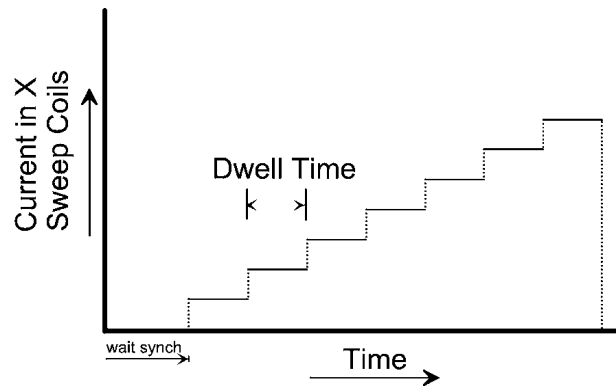

Figure 8-4 Schematic illustration of the staircase signal which is applied to the analog scan coils. Each *step* makes the electron beam move to the next location on the sample, or on the display CRT.

Given the capability of collecting and storing data in digital form, we can collect data from the various detectors over an area on the specimen by either 1) scanning the electron beam over an area on a stationary specimen (stationary relative to the x and y coordinates of the stage axis), or 2) scan the specimen over an area relative to a fixed beam by leaving the electron beam in "spot mode" and rastering the stage (specimen) under the beam. These two modes of digital imaging will be referred to as "*beam-rastered imaging*" and "*stage-rastered imaging*" respectively. Since you are already familiar with rastering of the beam, we will discuss digital, beam-rastering images first.

8.2.1 Beam-rastered images

Use of a digital scan generator allows the beam to be driven in both the X and Y directions in discrete steps rather than in a "constant velocity" mode as with a purely analog scanning system. A schematic view of a portion of an X-axis scan is illustrated in Figure 8-4. In contrast to the scan illustrated in Figure 8-1, a digital scan moves the beam in discrete steps. At each spot position, the beam remains stationary for a fixed amount of time, known as the *dwell*

time. At each one of these steps, the selected signals from the detectors are sent to the SEM computer for storage in appropriate memory frames.

By stepping (as opposed to true scanning) the beam in both the X and Y dimensions, the desired area on the sample is covered as illustrated in Figure 8-3. The size of the area scanned is simply determined by the magnification, and the area is that viewed on either the analog or digital monitor. One beam step in the X and Y directions defines a square *pixel*. For beam-rastered images, the electron beam is fully focused. This means that the pixel width can be considerably wider than the spot size, and this fact needs to be taken into consideration when setting up the instrument.

With reference to Figure 8-3, the pixel width corresponds to the step size between spots. Owing to the fact that the X and Y coordinates are binary, digital quantities, the number of steps along the X and Y axes usually have values of 2 raised to an integer power. Typical values include 2^7 (128), 2^8 (256), 2^9 (512), and 2^{10} (1024). For most purposes, we constrain the images to be square, and hence speak, for example, of 256 x 256 pixel, and 512 x 512 pixel images. The following table gives the total number of pixels (bytes and kilobytes) in commonly used images (each pixel being an 8bit byte).

| 128 x 128 | 256 x 256 | 512 x 512 | 1024 x 1024 |
|------------------|------------------|------------------|--------------------|
| 16,384 | 65,536 | 262,144 | 1,048,576 |
| 16k | 64k | 256k | 1024k = 1Mb |

The choice of the size of the area to be scanned (imaged or "mapped") determines the magnification of the microscope. This decision must be based on the grain size of the specimen and the resolution required for problem being addressed. For example, imaging of a 5 x 5 mm area at 256 x 256 resolution would clearly not be appropriate for a specimen in which the average grain size is less than 20 microns. Another consideration of choosing an appropriate pixel size is the spatial resolution of the information you are acquiring. For example, the interaction volume for x-ray generation is on the order of 1~3 microns ... it therefore doesn't make much sense to acquire elemental maps with pixel dimensions less than a micron. The operator should select a magnification and linear resolution appropriate to the problem being addressed.

In addition to the magnification - resolution issue, the operator must also consider the practical constraints of the time required to collect an image. As illustrated in Figure 8-4, data are collected for each pixel for a period of time known as the *dwelt time*. Dwell time is an operator-selected variable, and may range from 0.5 milliseconds (ms) to 20ms. Longer dwell times clearly will result in stronger signals, and the stronger the signal, the more useful it will be. At first glance, it might seem that the "best" signal would be achieved by selecting the largest possible dwell time. As noted on page 8-5, the quality of a digital image can be greatly improved by adding and/or averaging successive scans over the image. It therefore makes sense to select a

relatively short dwell time and average the signals over multiple scans of the electron beam. In this fashion, the signal-to-noise ratio is greatly enhanced, and any perturbations occurring during a single scan are minimized.

Prior to scanning an area on the specimen, the SEM is set up with the desired beam conditions (acceleration voltage, filament saturation, gun alignment, beam current, aperture selection, focus, etc., etc.). Since typical scans may require from 1 to 8 hours or more, it is important for the beam to be stable over the duration of the scan. Beam drift is partly compensated by performing multiple scans. It is a good idea, however to make sure that the filament has had sufficient time to completely warm-up and stabilize prior to the actual scan. The area to be scanned is determined with the microscope in manual operation.

Setup of the EDS acquisition is accomplished with the x-ray acquisition software. With this interactive software, parameters such as linear resolution, dwell time and selection of x-rays is accomplished. Collection of a representative x-ray spectrum is crucial for x-ray imaging. It is necessary to collect a spectrum representative of all the elements present in the area to be scanned. Once a representative spectrum is collected, it can be saved and stored for future use. In addition to collecting a representative x-ray spectrum, the operator must also define the MCA channels that will serve as the source for each of the element maps. This is accomplished by defining a *window* on the x-ray spectrum for each element included in the study. The accepted procedure is to set the width of each window to be that of the FWHM for each element peak. At this time it may be necessary to adjust the beam current so as to obtain the desired count rate and ²deadtime.

Each image is collected and stored as a *gray scale image* with 8bit precision³. This means that the "Z" parameter, or intensity of x-rays collected at each pixel may range from 0 to 255. Each image (i.e., BSE and the selected x-ray images) then consists of an array of pixels (262,144 for a 512 x 512 image) with the "brightness" of each pixel corresponding to a value between 0 and 255. The images, together or separately, are available for post-acquisition, image analysis. Some of the image analysis capabilities usually supplied by vendors include:

- Single Image Phase Analysis
- Multiple Image Phase Analysis
- Features Analysis
- Advanced Image Processing

² For maximum counts into a pixel value, deadtimes can approach 50%. However, be careful when evaluating ²deadtime ... 50% for when x-rays are collected from an oxide can produce ²deadtime can approach 100% when x-rays are emitted from a sulfide mineral. Therefore, if the acquisition stumbles upon a sulfide mineral the 100% ²deadtime can halt the project.

³ 16bit precision is also an option for x-ray counts, for which the values range from 0 to 65535. This precision is generally not needed as counts generally do not exceed 255 for short dwell times.

The use of these sophisticated image analysis packages depends largely on the nature of the project and the character of the specimens. The images acquired can also be downloaded from the image acquisition computer to a PC or MAC computer. Once transferred, they can be read and processed by a variety of software packages such as *Adobe Photoshop* or *Image-Pro Plus*.

A powerful method that represents what can be done with elemental maps is the *Multiple Phase Image Analysis* software. This software allows the analyst to use the *qualitative* data in a collection of elemental maps and create *quantitative* phase or mineral maps ... for example, 33% quartz, 29% plagioclase, 23% clinopyroxene, 13% orthopyroxene and 0.6% apatite. For the petrologist who wants better accuracy than typical point counting and also wants to remove the subjective nature of optically identifying minerals (especially if the tedious task is delegated to several students).

Figure 8-5 Elemental map of magnesium in a metamorphosed olivine bearing dolomite marble (top); its histogram which indicates the region selected as representative of olivine (middle), and the resulting true-false bitmap (bottom).

Figure 8-5 (right) shows the original magnesium elemental map for an olivine bearing marble, together with its image histogram that indicates how many pixels are associated with a specific gray-level (0-255). Note that calcite is represented by no Mg (black), and forsterite and clino-humite are associated with bright areas ... with dolomite being represented by some intermediate gray level. Quantitative phase analysis begins with selecting a region of the histogram, which is representative of the mineral, and asking the software to simply

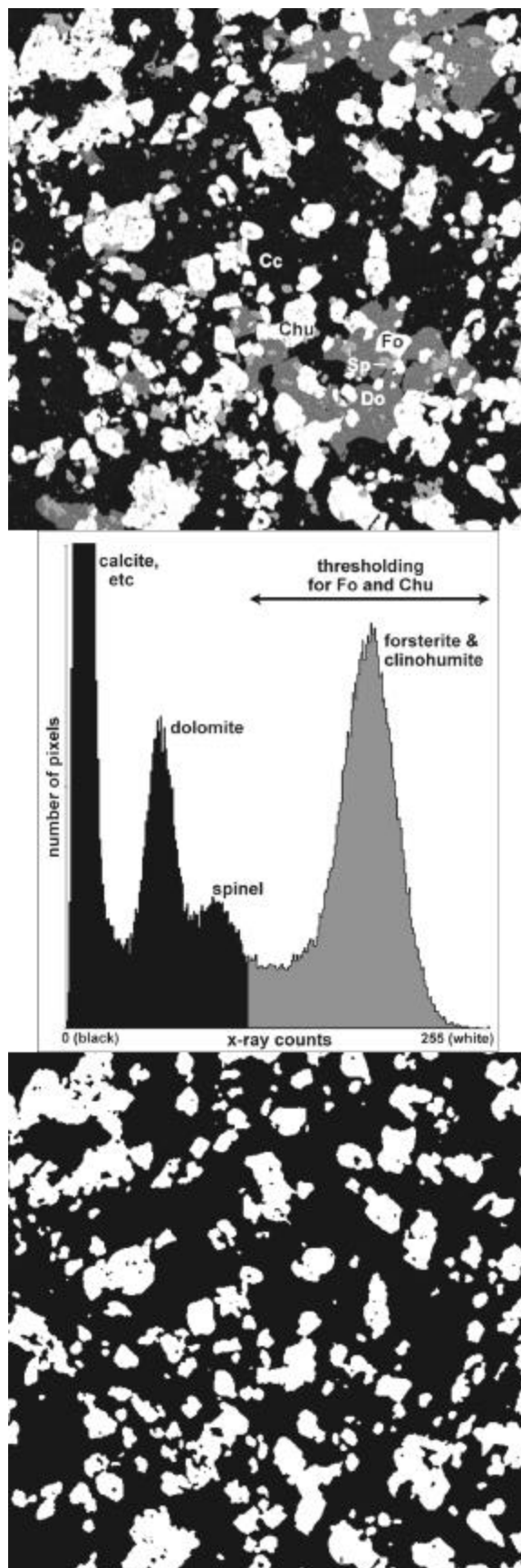

display it in the form of a true-false map ... that is, a white on black image (fig 8-5 bottom).

However, we are not finished yet ... we only have a map for olivine and its alteration phase, clinohumite. If we also use the fact the clino-humite also contains minor titanium, then we can use a similar process to show us where any Ti is associated with the T/F map we just created. To refine the process we could even use the silicon map to make sure we're looking at only silicate minerals. Ultimately, we would use the logical operator *AND* to show us where bright Mg is true *AND* where Ti above detection is true *AND* where silicon below detection is true, which yields a finished T/F map indicating which pixels are true for all the criteria. All that remains is counting the white pixels and yielding a special percentage. For primary and secondary minerals the accuracy can be to 2 or even 3 significant digits. The process should not overlook trace minerals either (e.g., apatite), so the analyst will need to suspect their presence and look for them.

8.3 Glossary of terms for image files

File format. Images, as files, need to include information. For example, an image as *raw* data doesn't include any information about the number of pixels horizontal or pixels vertical. If you were to ask Photoshop to open an image file as "RAW" you would need to provide the information (including (see below) number of channels and channel depth). *File formats*, such as the *tagged image file format (TIF)*, include such information and more. Other examples of file formats are PICT, Sun Raster, Photoshop (PSD), bitmap (BMP), and many others. Some formats imply a special compression technique, *JPEG* for example (see compression below).

File formats differ, depending on their application focus. For example, the PICT format can also be used for "vectored" objects, which is what are created with *draw* programs (e.g., "draw a box on the page and fill it with red" is different from defining a pixel *bitmap*, red pixels amongst white pixels). Various types information are either stored at the beginning of a file (file header) or at the end (footer). Other types of information that can be included in the file header include *text strings* that might label the author, date created, copyright information, and definitions for printing, or possibly a user defined palette of colors. Another example, of such a *tag* can be magnification and other instrumental parameters. (Although it is unfortunate that software other than the OEM vendor's usually cannot find or read these tags.)

Channels. Some images have a number of *channels or spectral bands*. For example, color images have 3 or possibly 4 channels which represent how the colors are represented by red, blue and green (RGB); or cyan, magenta, yellow and black (CMYK); or hue, saturation and intensity (HSI). SEM images, whether secondary electron, backscatter electron, or elemental maps, are always single channel or grayscale images. On the other hand, if you had a collection of 8 elemental maps, which represented the spatial distribution of 8 elements for a unique area, then you might consider each map to be a channel ... although combining more than 4 as a meaningful representation would not be straightforward.

Depth of channel or pixel depth. *Depth* is sometimes used as a measure of the number of levels or shades of color. For example, *8bit depth* is the same as saying 256 (2^8) levels of gray. This can be important for our applications because 8bit depth is generally inadequate for WDS x-ray counting which can sometimes exceed 1000 counts per pixel. For WDS, and sometimes EDS, we will acquire with 16bit depth (65536 levels) and the TIF format can accommodate 16bit data, as can *Photoshop* and *Image Pro Plus*.

8bit color or 24bit color. A special single channel color image format is GIF. Normally color images are represented with 16 million colors, a combination of three 8bit channels, typically RGB. Imagine a single channel grayscale (256 grays). Now imagine putting a 256 color palette at the end with a one-to-one correspondence of a pixel value of (e.g.) 127 is mapped to the 127th color in the palette, and that color is simply the 127th gray level. We now have an “indexed” grayscale⁴ image. Now imagine defining the 127th color in the palette as any color you need ... now you have what is usually referred to as an “8bit indexed palette”. If 256 colors can adequately represent the original 24bit color image then you’ve made the image’s file 1/3 its original size.

Indexed palettes are commonly used for *pseudo-coloring* a grayscale image. For example, if it helps the presentation of your image data it might be appropriate or useful to map a carefully chosen collection of 256 colors to the grayscales. This could be, for example, the color range of the rainbow or the same color range attributed to black body radiation (thermal scale).

⁴ This is an important distinction for some software. For example, some image software packages write TIF formatted files with an indexed grayscale palette. Photoshop will not offer any of its image filters unless the image is pure grayscale. Therefore, in order to edit these “indexed palette” images, you first have to have Photoshop convert the image’s mode from *indexed* to *grayscale*. This causes absolutely no loss of information.